

REV	DATE	DESCRIPTION	DRAWN	CHECKED
-	27/01/21	DRAWING CREATED	MF	MF

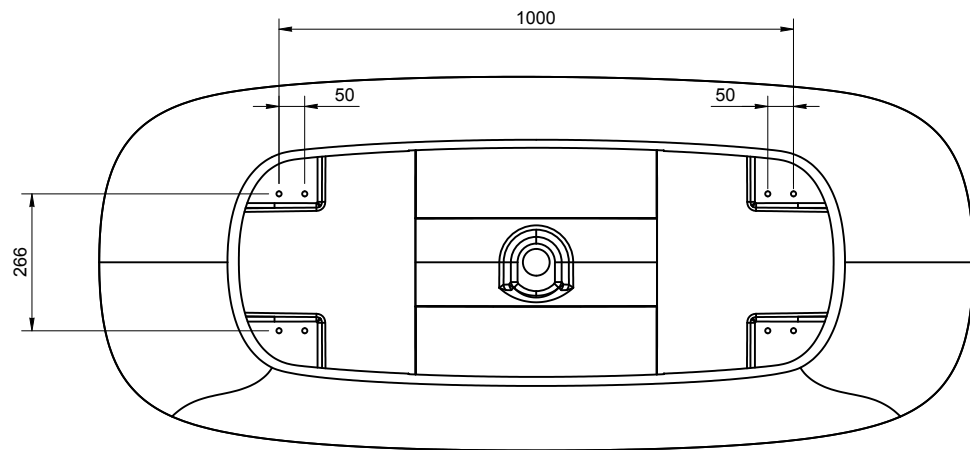
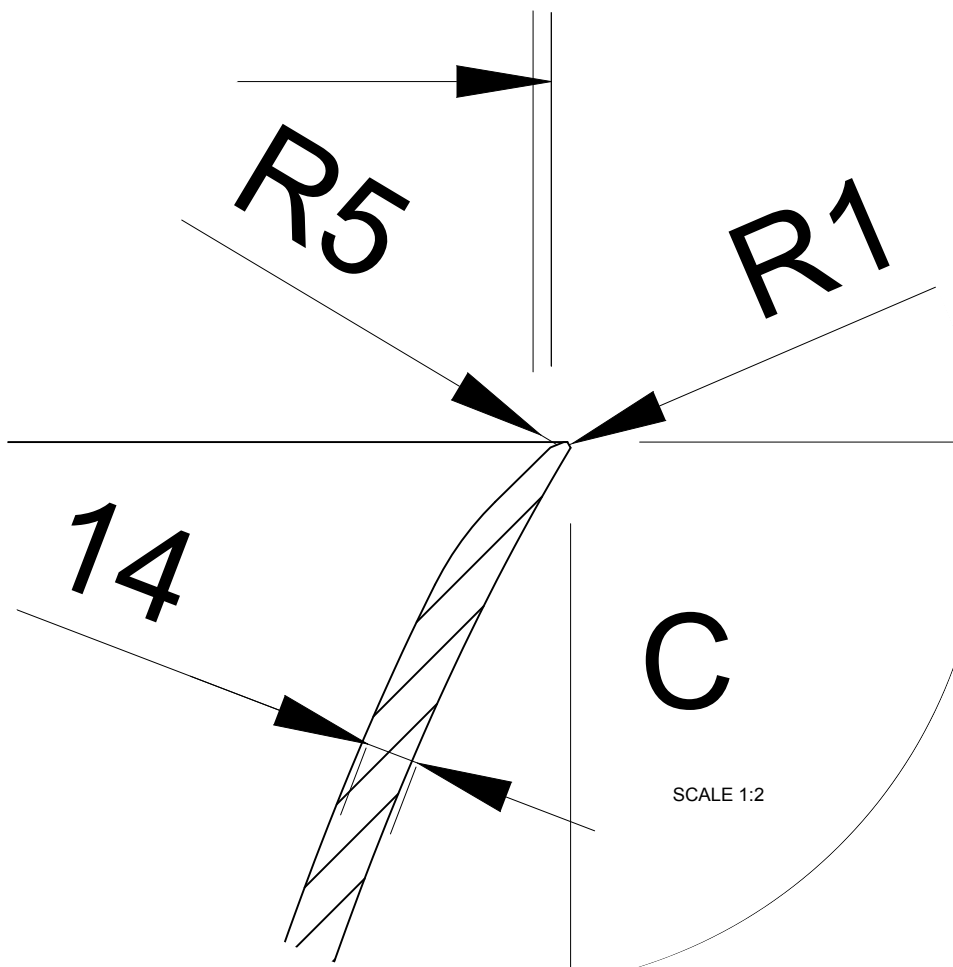
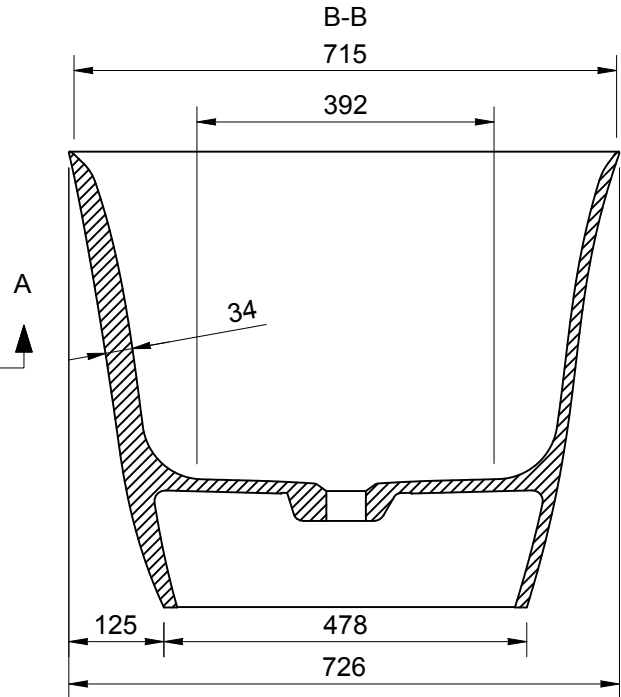
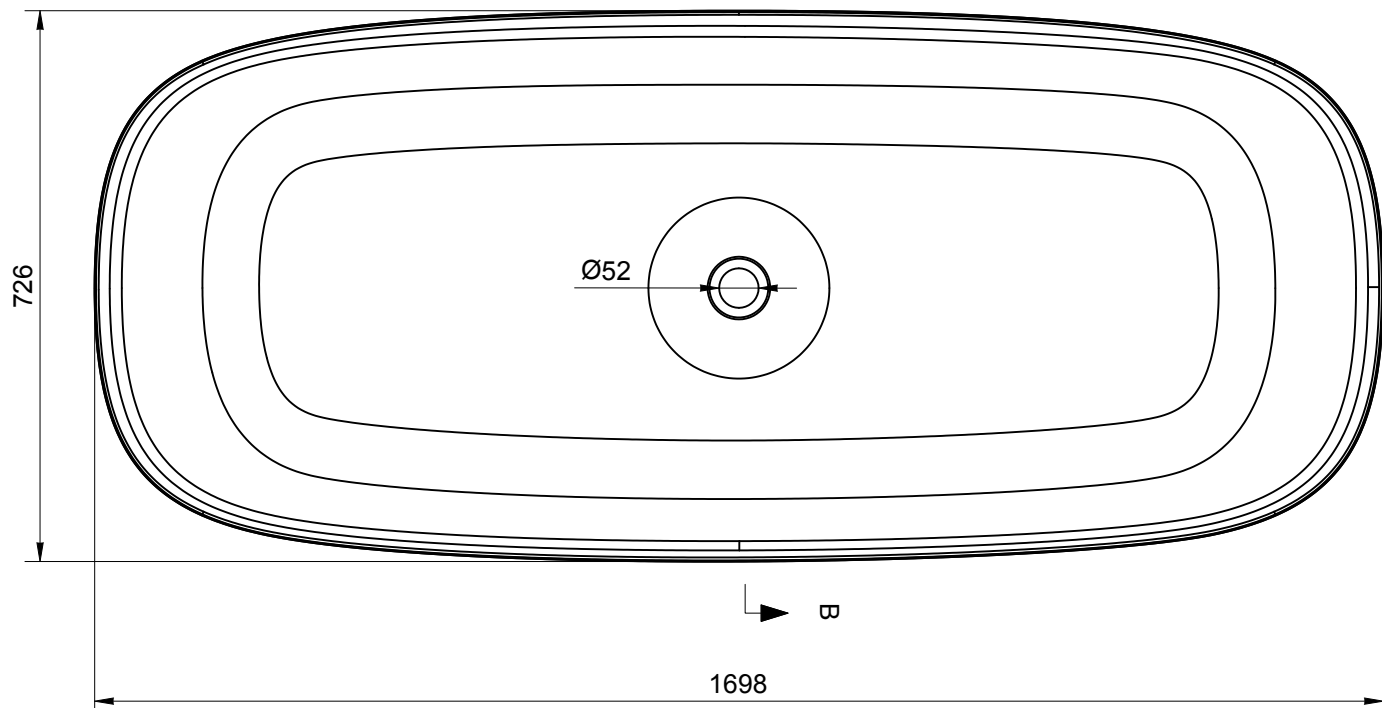
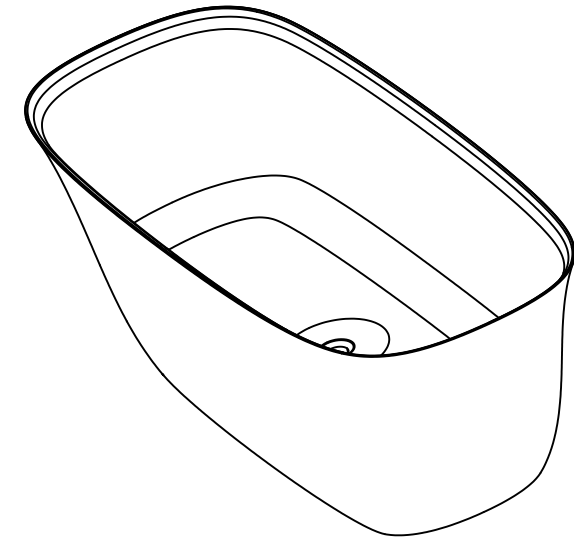
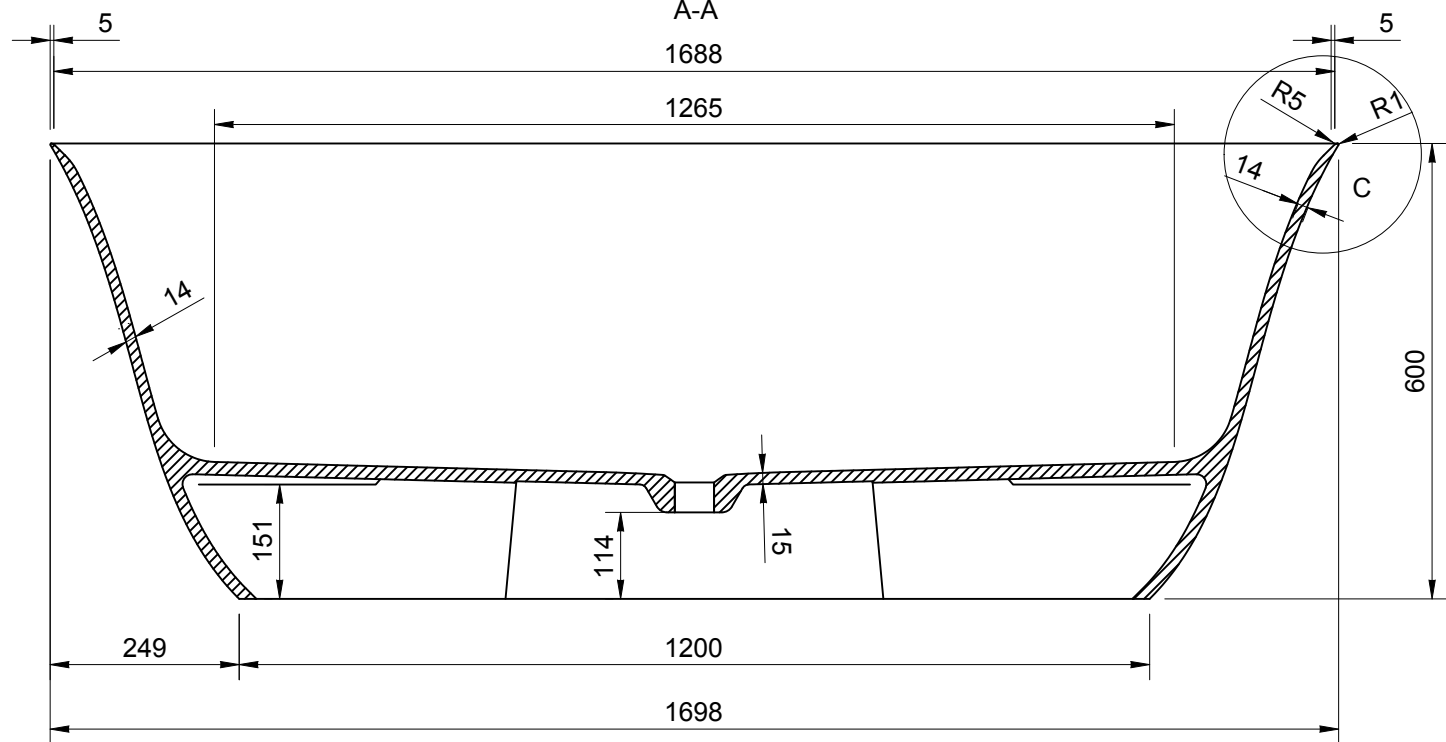

BOTTOM VIEW NOT TO SCALE

NOTE
M10 STEEL BEARINGS

TOLERANCE LENGTH / WIDTH / HEIGHT	+10/ -10mm	CREATED	DRAWN BY	CHECKED BY	DRAWING TITLE	DRAWING No.	CURRENT REV.	VARIANT 1 - GLOSS FINISH	HOC-GW	SHEET	SHEET SIZE	SCALE	
TOL. PLANE BENDING	≤ 800mm	+1.5/ -1.5mm	27/01/21	MF	HOCKNEY BATH	HOC	-	HOC-MW	1/1	A3	1:10	1698 X 726 X 600	
	> 800mm	+3 / -3mm											
TOLERANCE HOLES LOCATION		+3 / -3mm							NO	0	BATH VOLUME		
TOLERANCE HOLES DIAMETER		+1 / -1mm							REGULAR		FULL = 350L		
TOLERANCE WALL THICKNESS		+1 / -1mm									OVERFLOW= ***L		
TOLERANCE FEET LOCATION		+5 / -5mm											
								NET WEIGHT	GROSS WEIGHT				
								121.72kg	135kg				



THE
LUXURY BATH
COMPANY