

1 2 3 4 5 6 7 8

A B C D E F

A B C D E F

Invisible edges

Anti-slip structure MS012

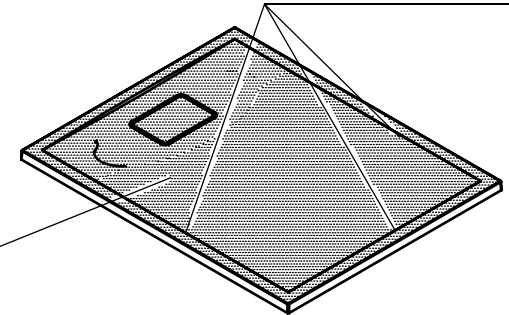

Bottom view

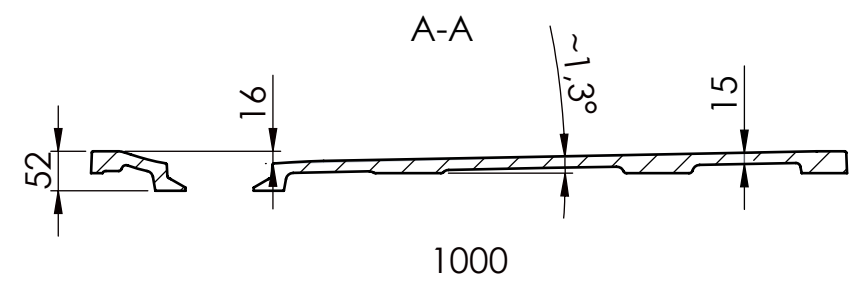
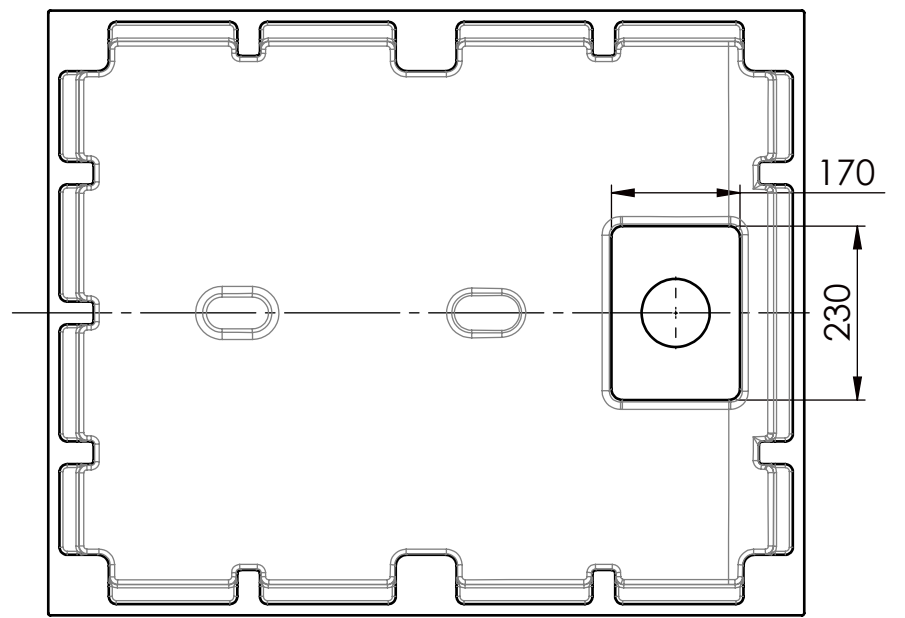
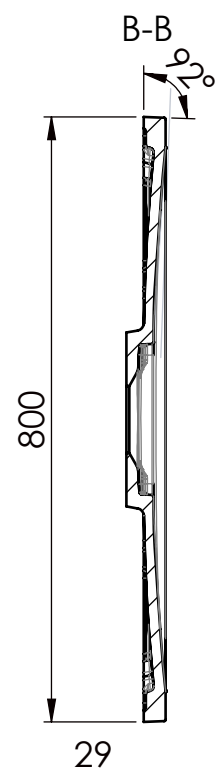
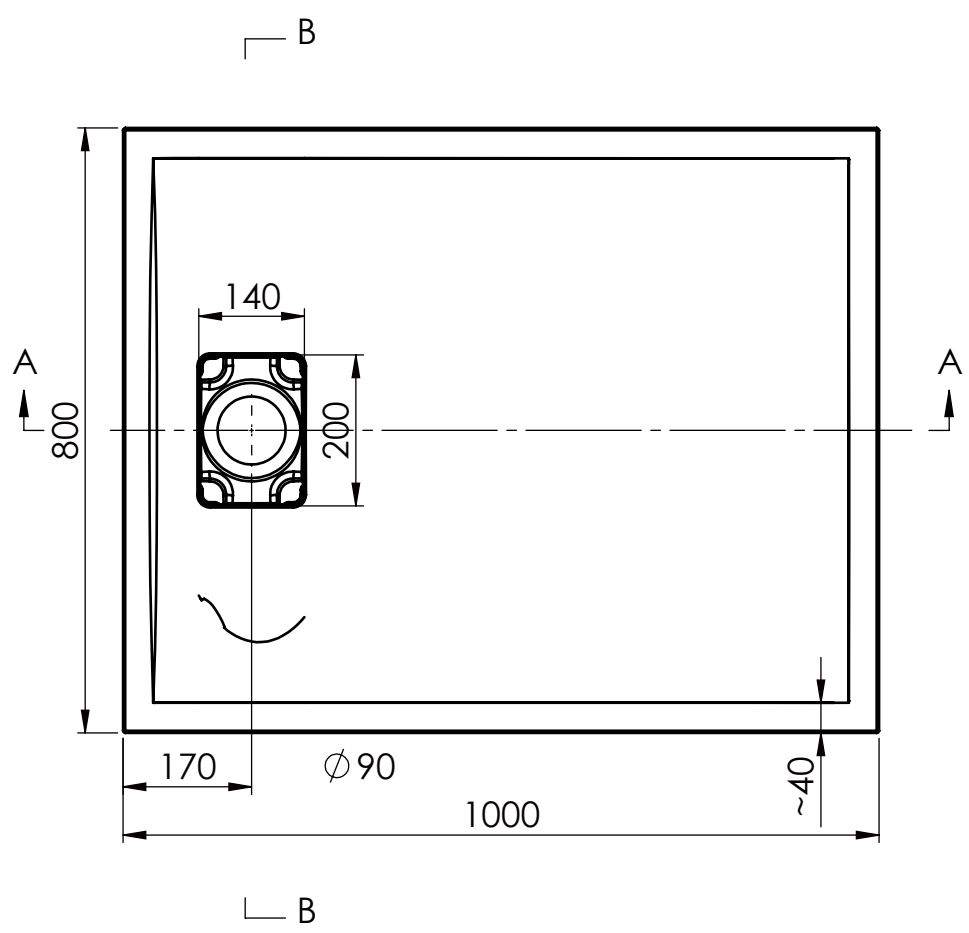

TOLERANCE LENGTH / WIDTH		+5/0mm		CREATED	DRAWN BY	CHECKED BY	DRAWING TITLE	DRAWING No.	CURRENT REV	SHEET	SHEET SIZE	SCALE	
TOLERANCE HEIGHT		+2/-2mm		01/01/24	MF	MF	TURNER 1000 X 800 SHOWER TRAY	TUR-ST-MW-10X8	-	1/1	A3	1:10	
TOL. PLANE BENDING		≤ 1200mm	+2 / -2mm	<div style="border: 1px solid black; padding: 5px; display: inline-block;"> THE LUXURY BATH COMPANY </div>									
		> 1200mm	+3 / -3mm										
TOLERANCE THICKNESS		+2 / -2mm											
TOLERANCE FEET LOCATION		+7 / -7mm											
TOLERANCE HOLE OCATION		+2 / -2mm											
TOLERANCE HOLE DIAMETER		+1 / -1mm											
OVERFLOW	NO	WASTE COVER	COVER	TAPHOLE	0	MAIN DIMENSIONS		1000 X 800 X 29					
NET WEIGHT	31.2kg	GROSS WEIGHT	35.2kg										

1 2 3 4 5 6 7 8