

Bottom view

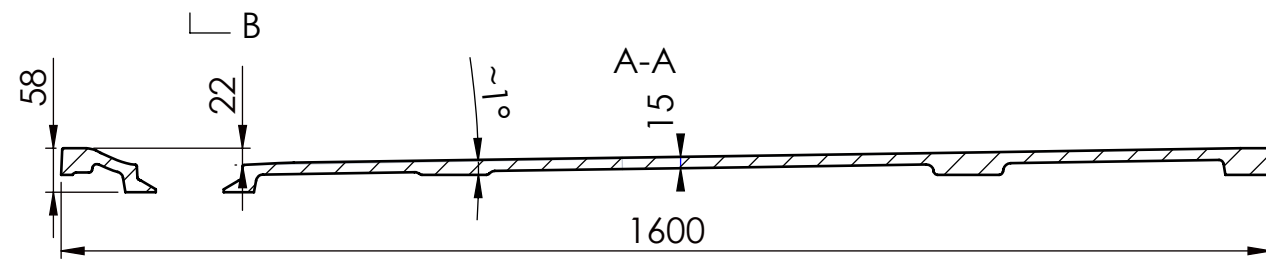
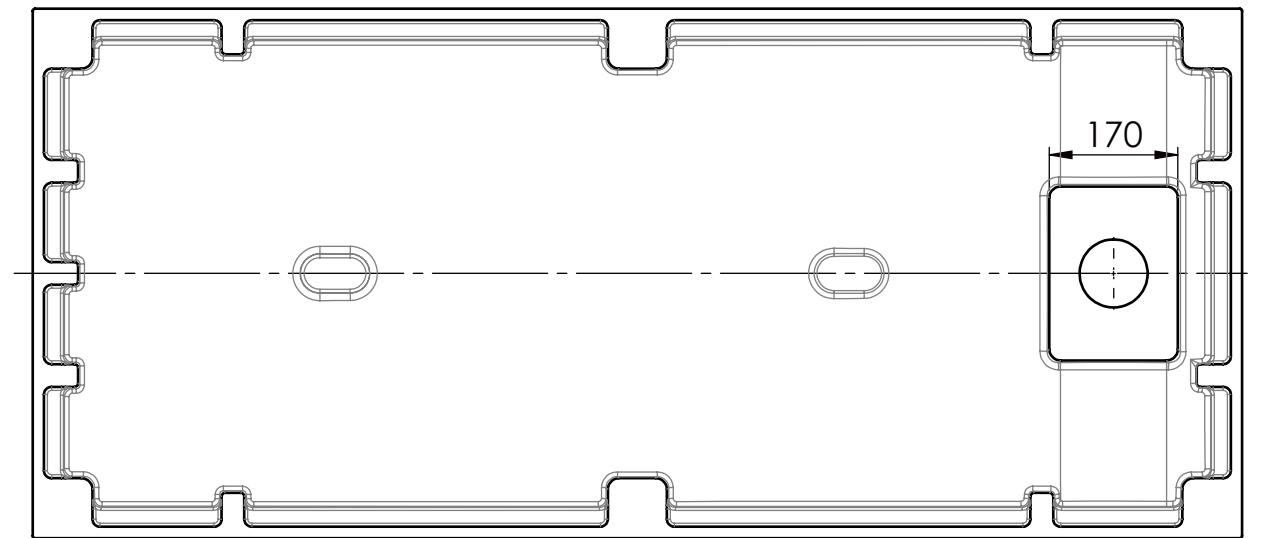
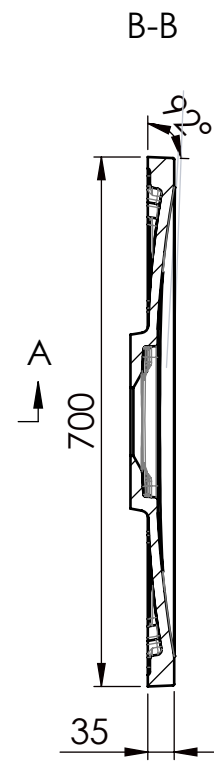
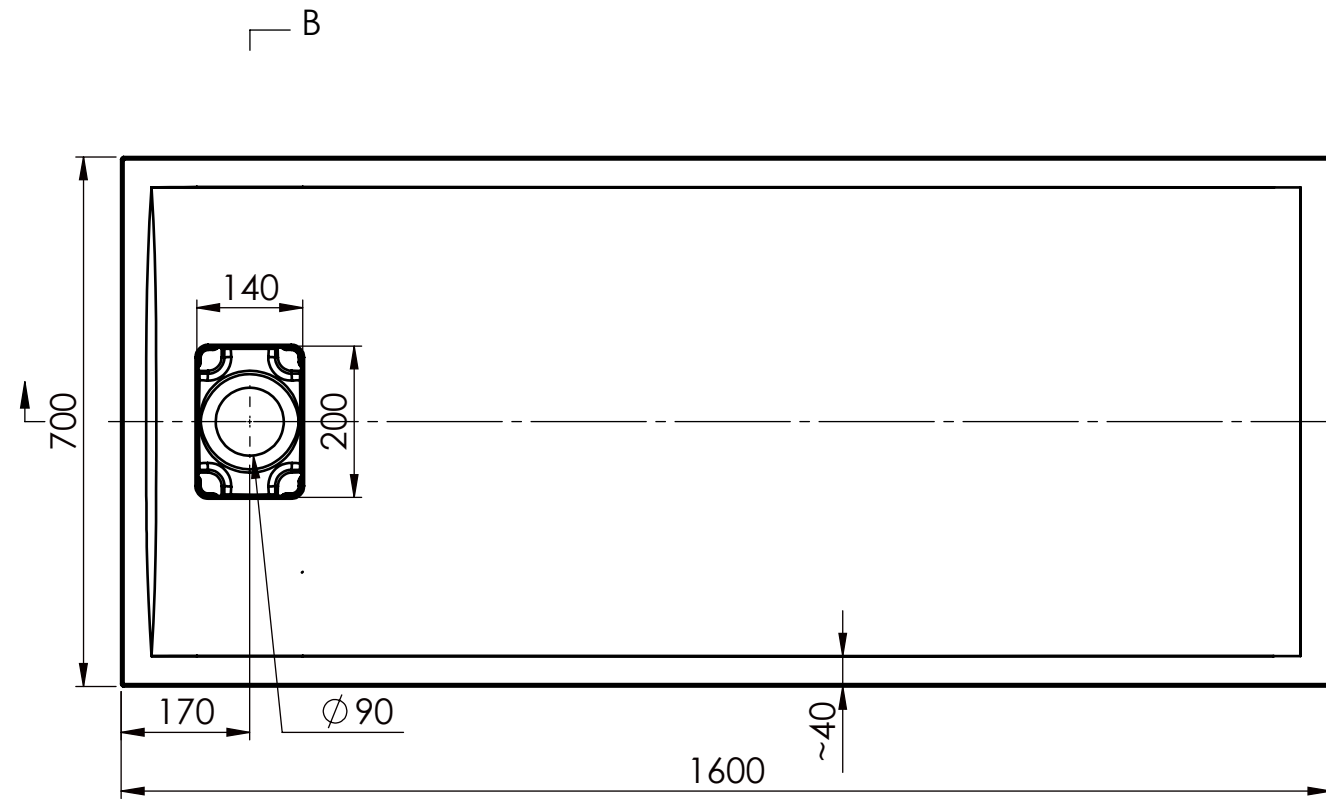

B-B

TOLERANCE LENGTH / WIDTH	+5/0mm	CREATED	DRAWN BY	CHECKED BY	DRAWING TITLE
TOLERANCE HEIGHT	+2/-2mm	01/01/24	MF	MF	TURNER 1600 X 700 SHOWER TRAY
TOL. PLANE BENDING	≤ 1200mm: +2 / -2mm > 1200mm: +3 / -3mm				
TOLERANCE THICKNESS	+2 / -2mm				
TOLERANCE FEET LOCATION	+7 / -7mm				
TOLERANCE HOLE LOCATION	+2 / -2mm				
TOLERANCE HOLE DIAMETER	+1 / -1mm				

DRAWING No: TUR-ST-MW-16X7
CURRENT REV: -
SHEET: 1/1
SHEET SIZE: A3
SCALE: 1:10



THE LUXURY BATH COMPANY

OVERFLOW	WASTE	TAPHOLE	MAIN DIMENSIONS
NO	COVER	0	1600 X 700 X 35
NET WEIGHT	GROSS WEIGHT		
46kg	50kg		