

Bottom view

B-B

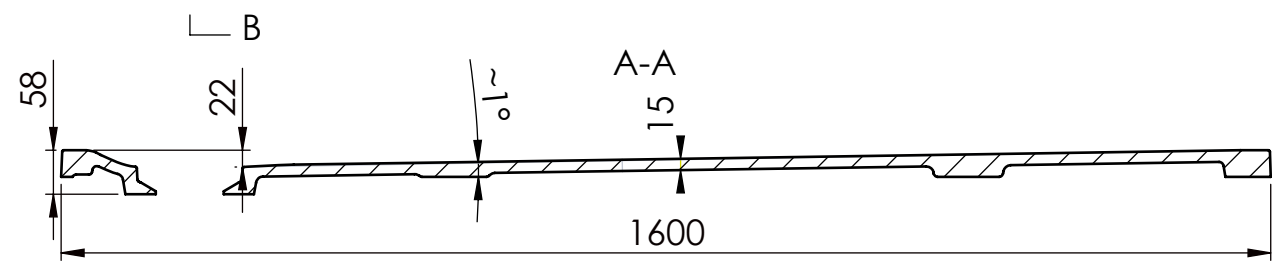
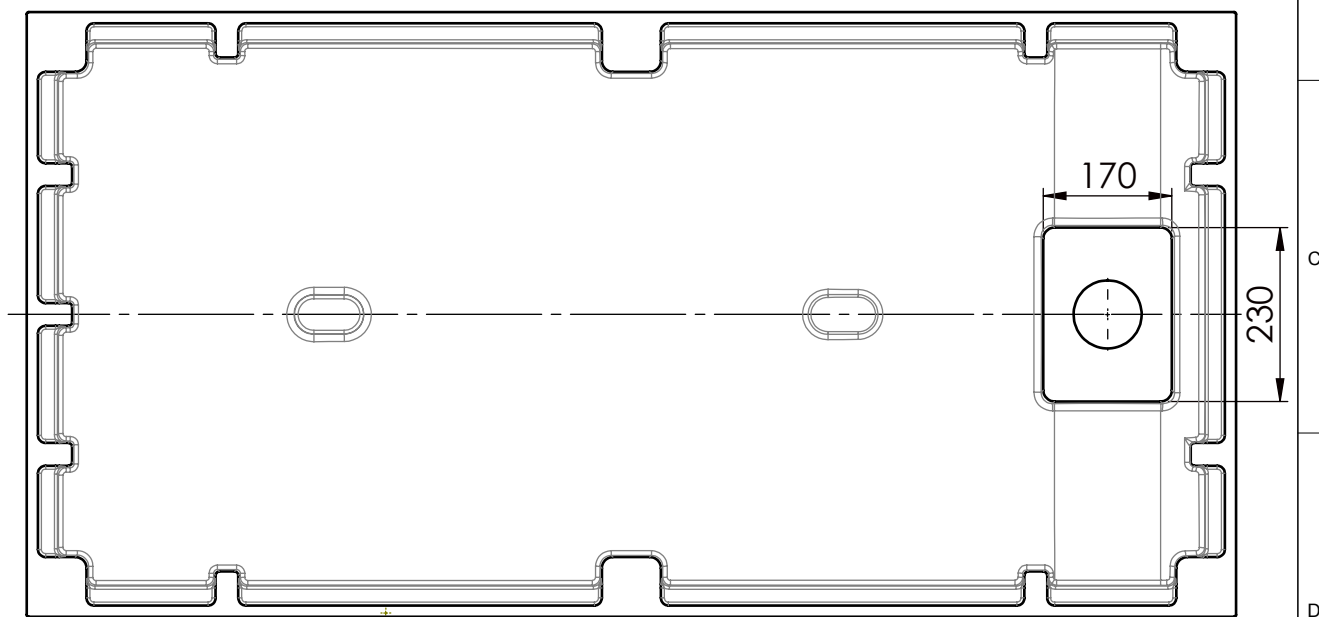
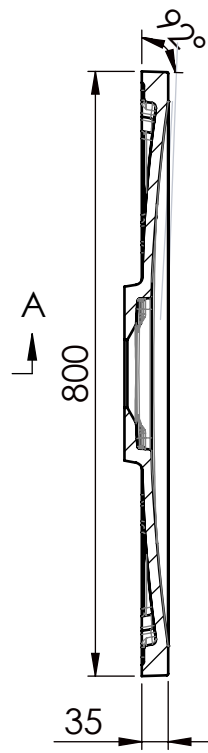
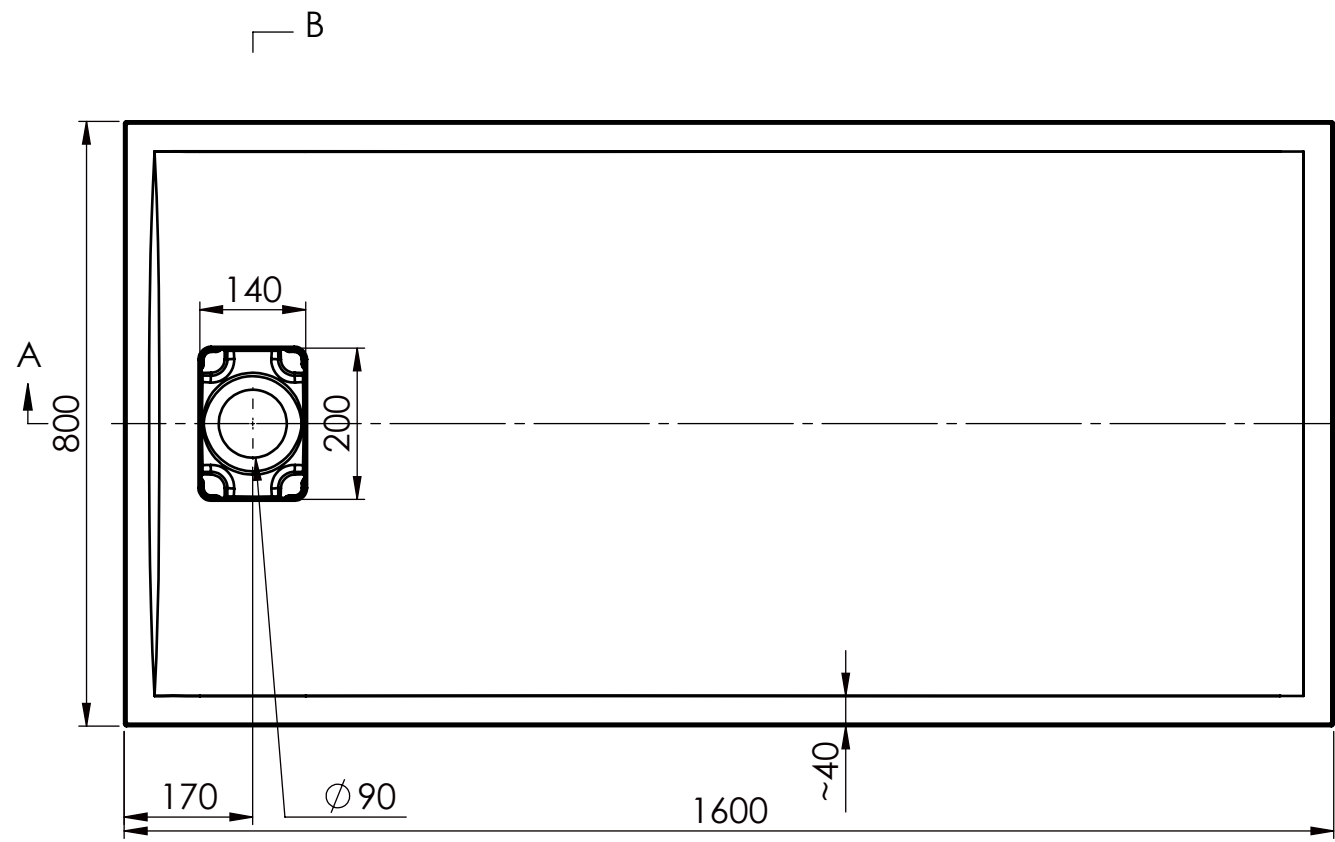

TOLERANCE LENGTH / WIDTH	+5/0mm
TOLERANCE HEIGHT	+2/-2mm
TOL. PLANE BENDING	≤ 1200mm +2 / -2mm > 1200mm +3 / -3mm
TOLERANCE THICKNESS	+2 / -2mm
TOLERANCE FEET LOCATION	+7 / -7mm
TOLERANCE HOLE LOCATION	+2 / -2mm
TOLERANCE HOLE DIAMETER	+1 / -1mm

CREATED	DRAWN BY	CHECKED BY	DRAWING TITLE
01/01/24	MF	MF	TURNER 1600 X 800 SHOWER TRAY

DRAWING No.	CURRENT REV	SHEET	SHEET SIZE	SCALE
TUR-ST-MW-16X8	-	1/1	A3	1:10



THE LUXURY BATH COMPANY

OVERFLOW	WASTE	TAPHOLE	MAIN DIMENSIONS
NO	COVER	0	1600 X 800 X 35
NET WEIGHT	GROSS WEIGHT		
51.7kg	55.7g		